

Measuring with a protractor (2)

1 Circle the greater angle in each pair.

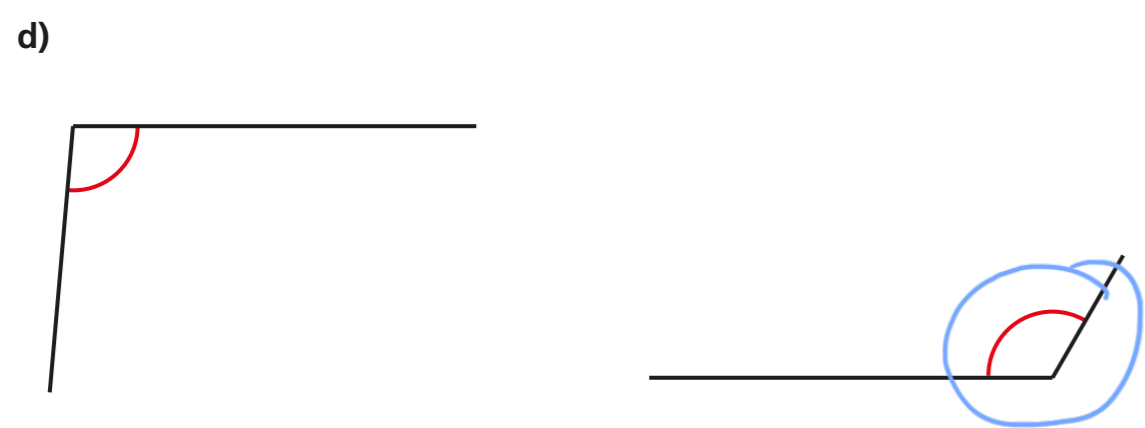

2 What is the size of the angle marked in each diagram?

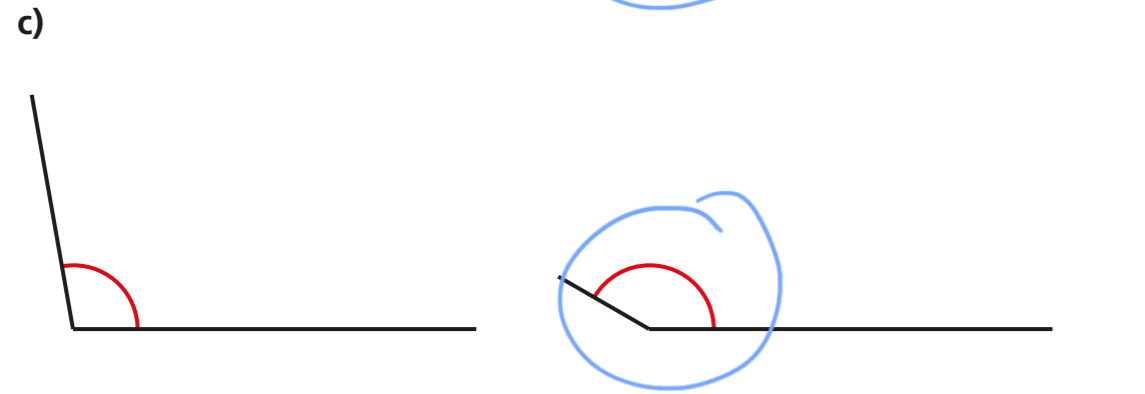
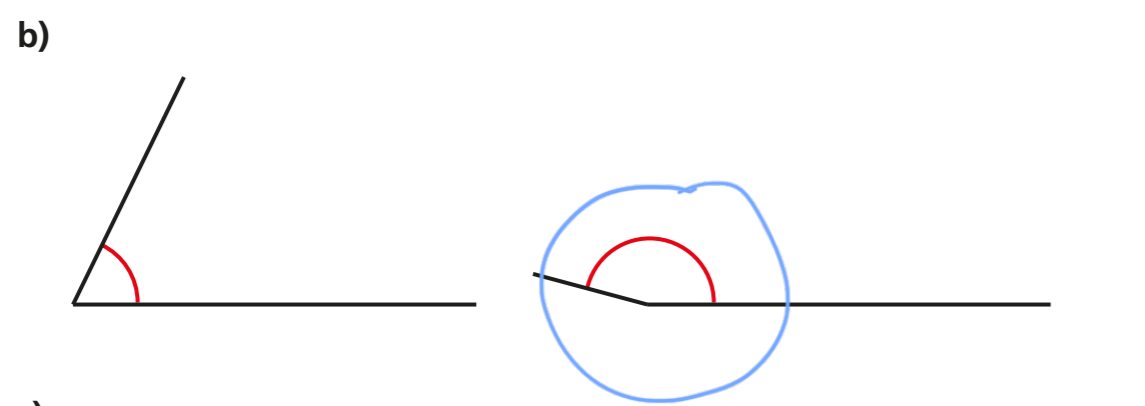
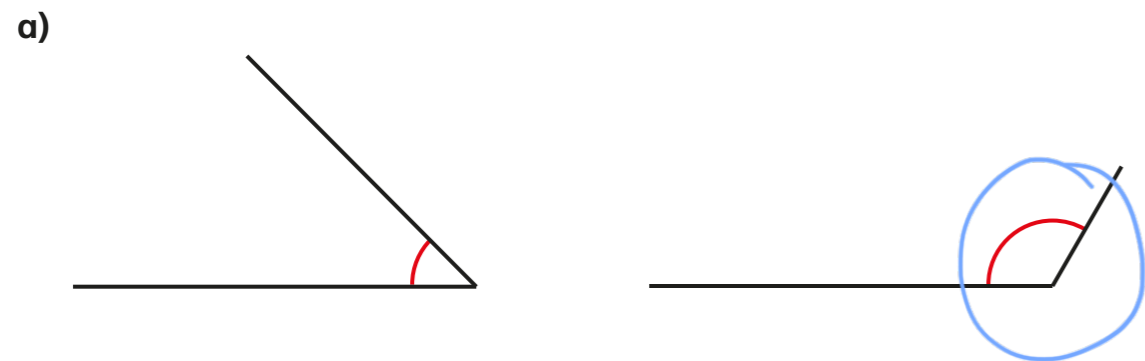
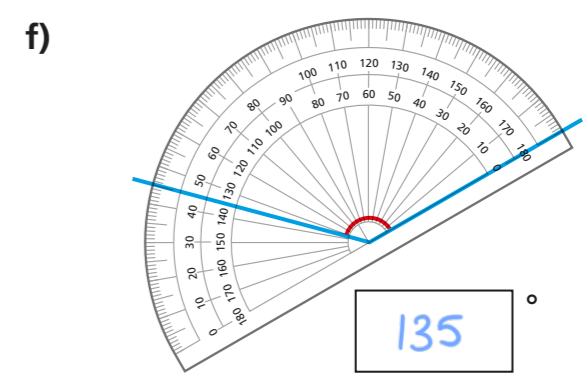
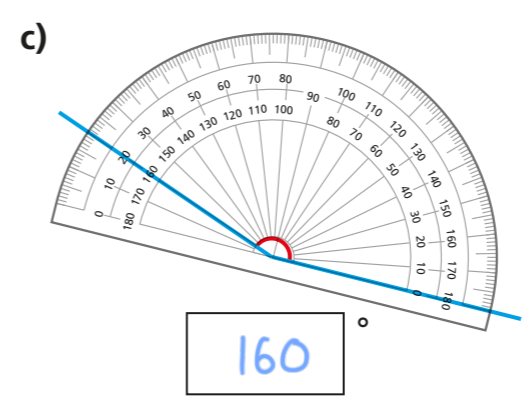
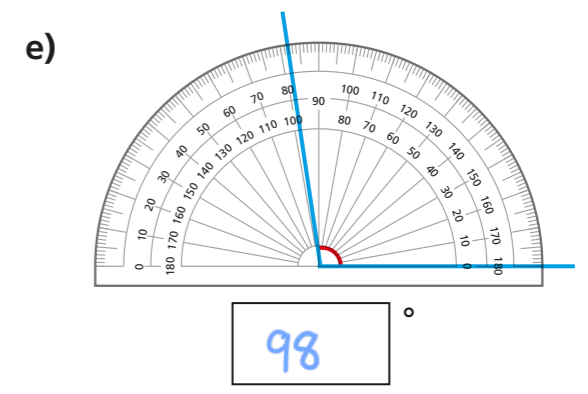
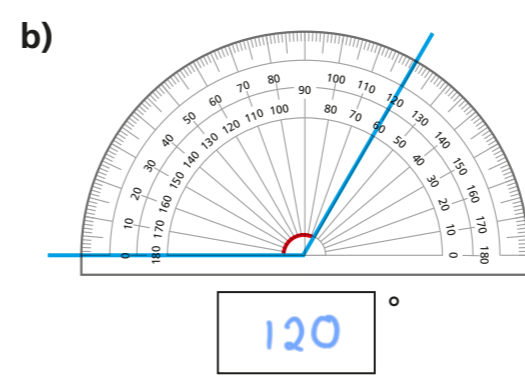
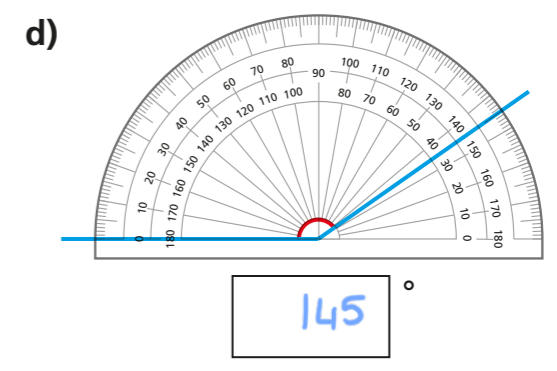
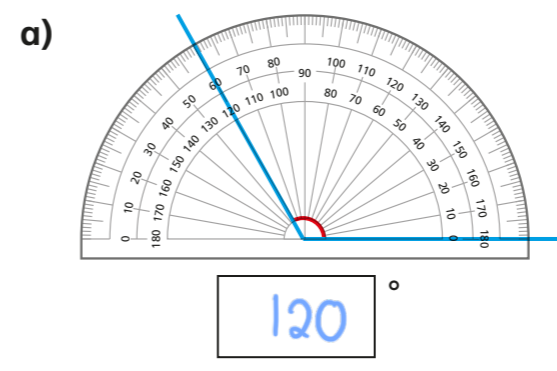

3



The angle marked is 30 degrees.

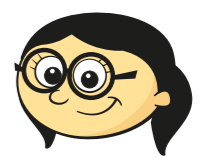

a) How do you know, just by looking at the angle, that it is not 30 degrees?

It is greater than 90°

b) What mistake do you think Annie has made?

She has read the wrong number off the protractor.

- 4 Scott is trying to measure the obtuse angle.

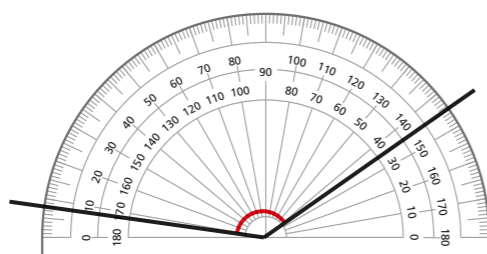

What mistake has Scott made?

The protractor isn't lined up with one of the lines from the angle so he isn't measuring from 0

- 5 Measure each of the angles.

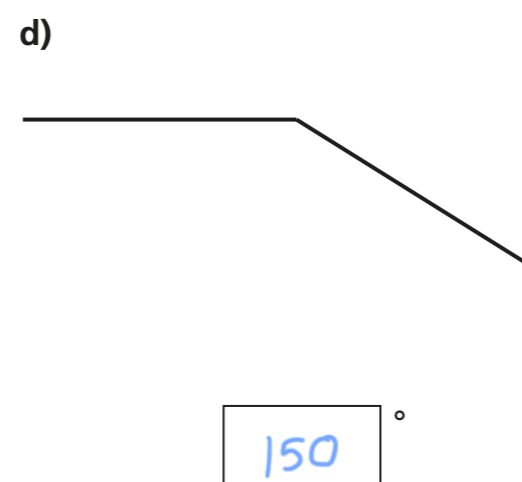
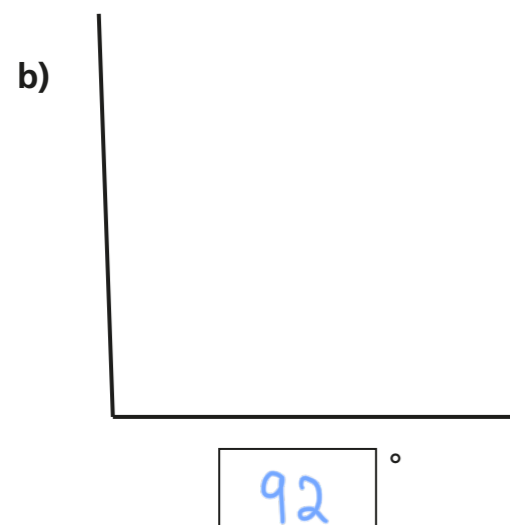
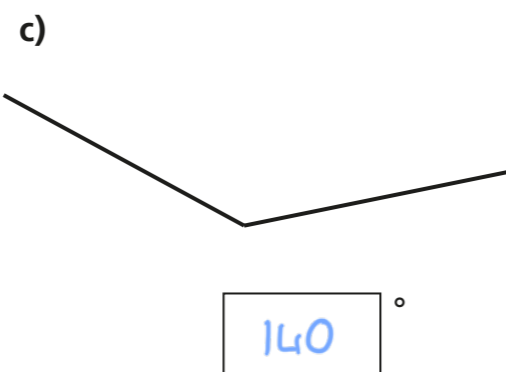
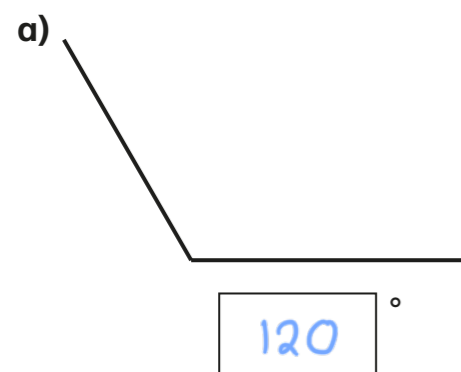

- 6 Eva puts one ice-lolly stick over another ice-lolly stick.

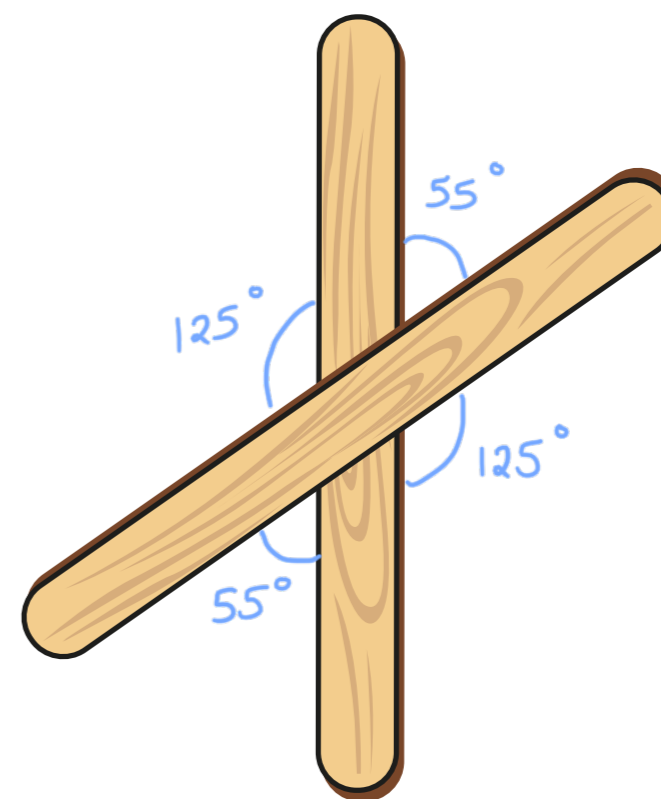

- a) Estimate the size of the largest angle between the two ice-lolly sticks.

My estimate is °.

- b) Measure the angle to check your estimate.

The actual measurement is °.

- c) Measure the size of each of the angles formed by the ice-lolly sticks and label them on the diagram.

- d) Use ice-lolly sticks to create different sized angles and measure them.



Drawing lines and angles accurately



1 Draw each of the angles accurately.
Use the line provided as part of your angle.

a) 60 degrees



b) 85°



c) 110°



d) 143°



2 Dexter is asked to draw an angle of 30 degrees.
He marks a point as shown.

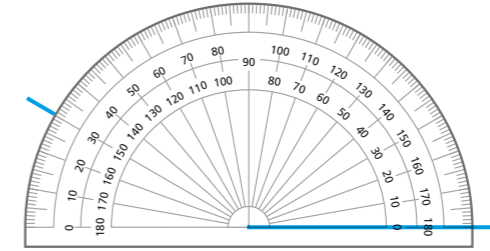

What mistake has Dexter made?

3 Draw an angle of 100° on each line.
Use the lines to form part of the angle.

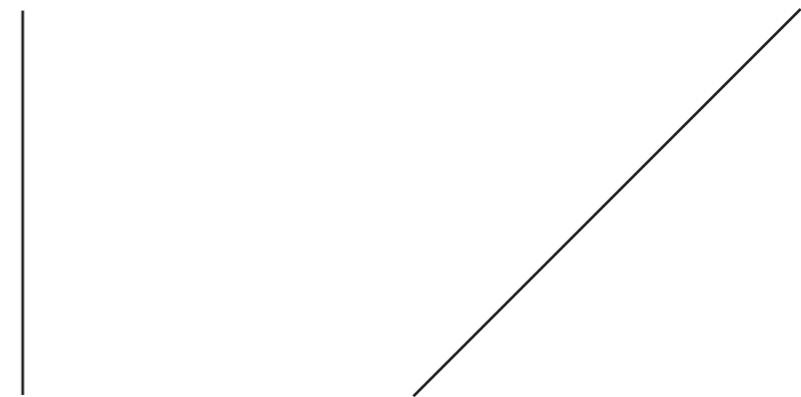



- 4 Draw three angles that all measure 55° .
Each angle should be in a different orientation.

e.g.

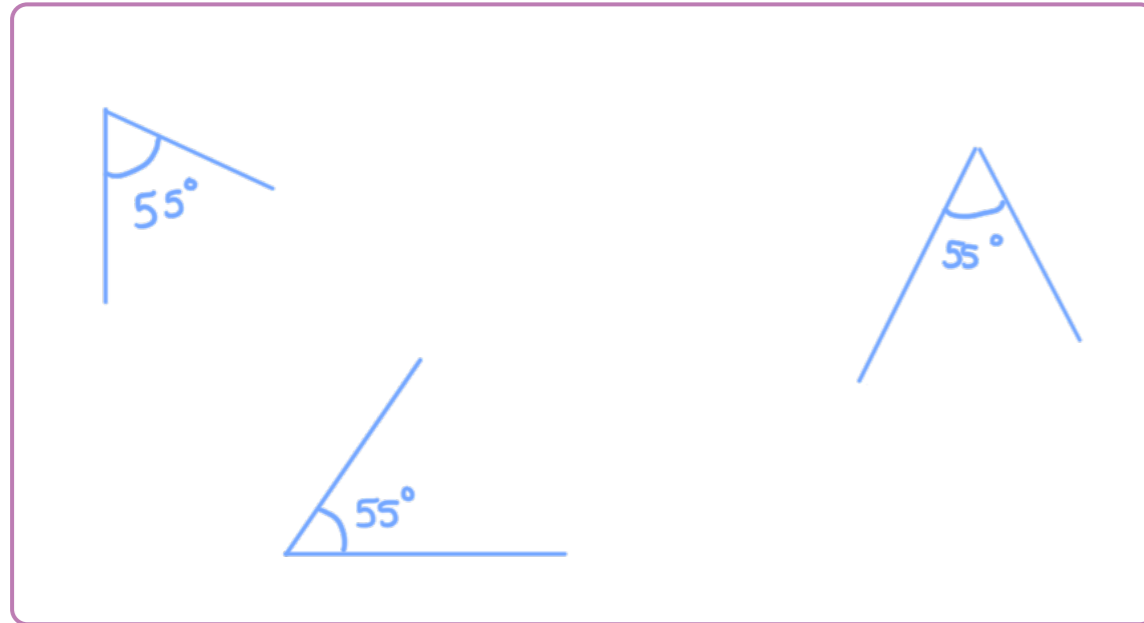

- 5 Draw these lines and angles accurately using a ruler and protractor.

a)

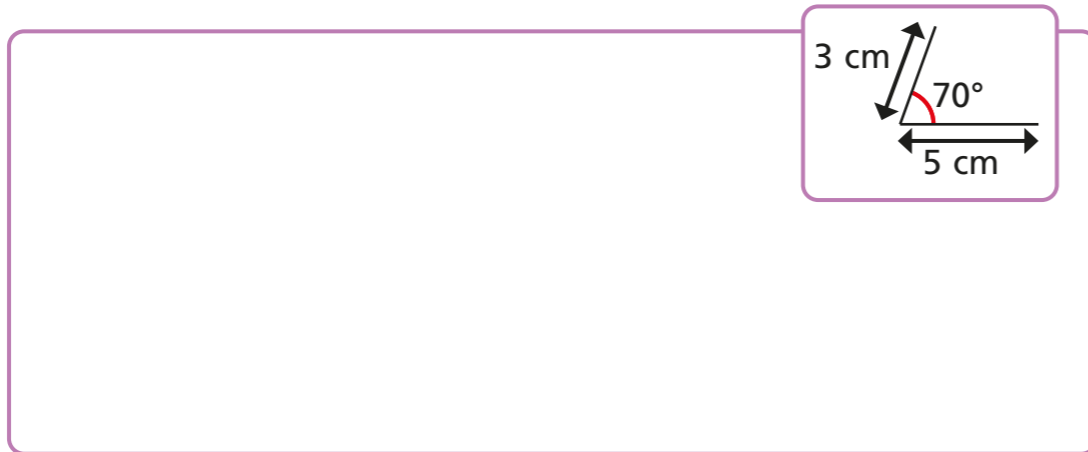

b)



- 6 Make an accurate drawing of the shape.

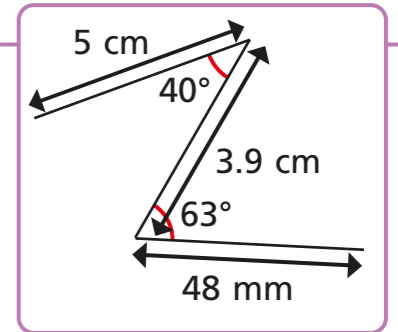
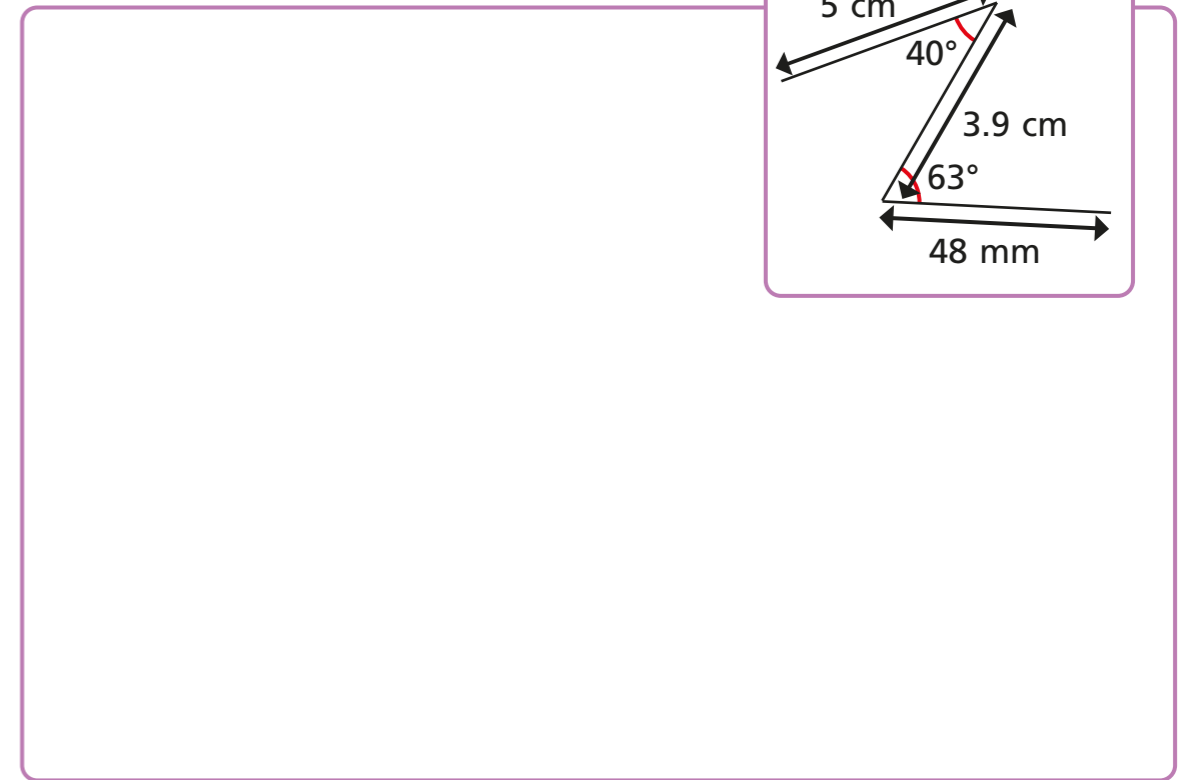

- 7 Draw the triangle accurately and work out its perimeter.

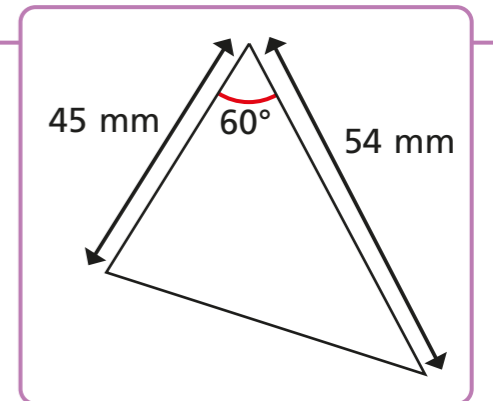
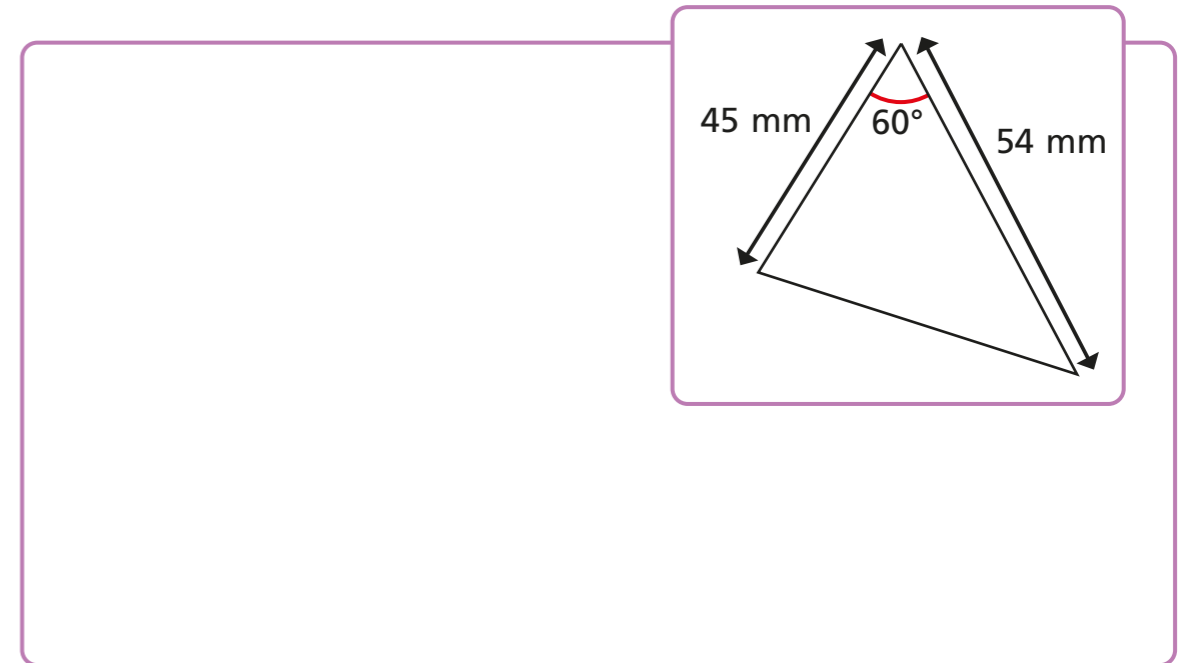

perimeter = mm



Calculating angles on a straight line

1 Work out the sizes of the unknown angles.

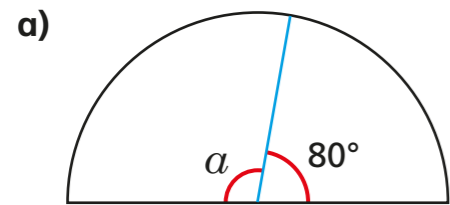

$a = \boxed{100}^\circ$

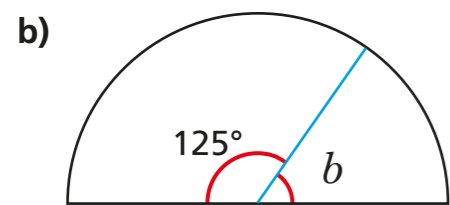

$b = \boxed{55}^\circ$

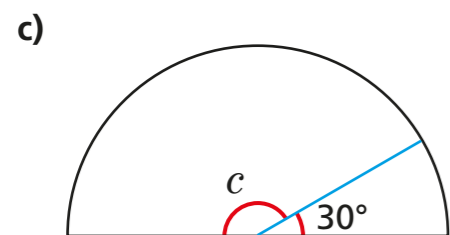

$c = \boxed{150}^\circ$

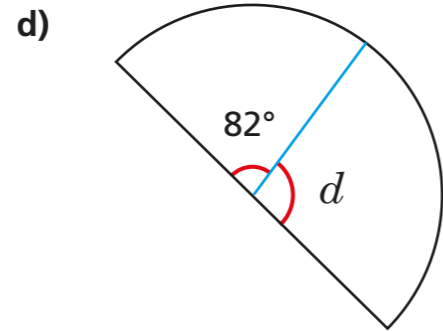

$d = \boxed{98}^\circ$

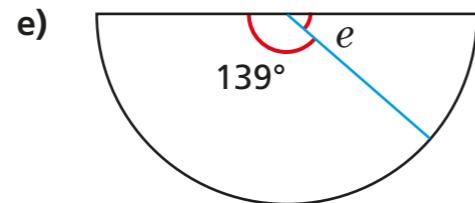

$e = \boxed{41}^\circ$

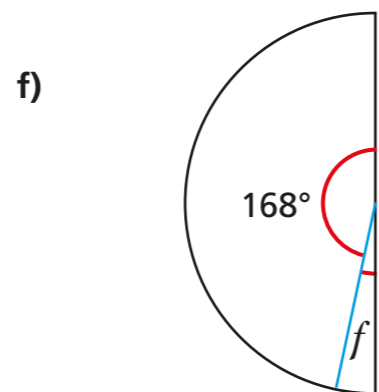

$f = \boxed{12}^\circ$

2 Work out the size of the unknown angles.

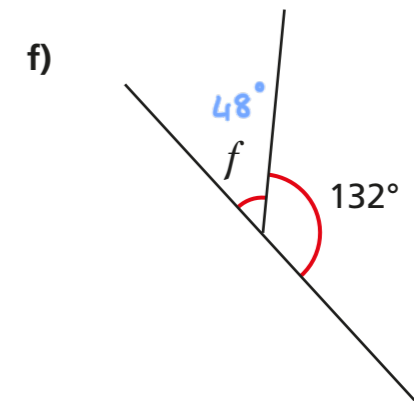
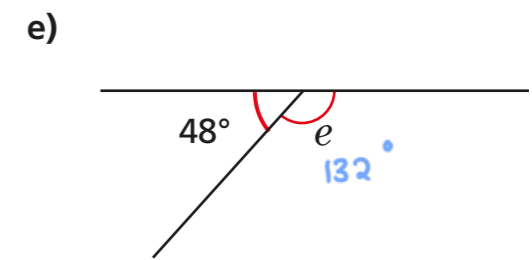
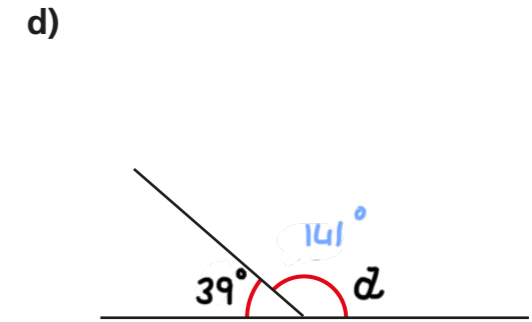
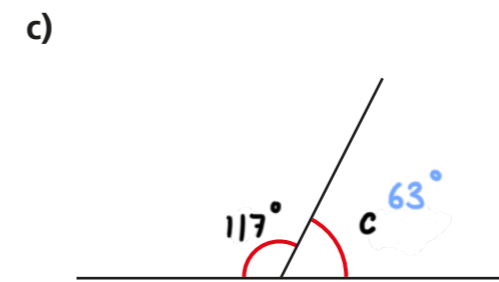
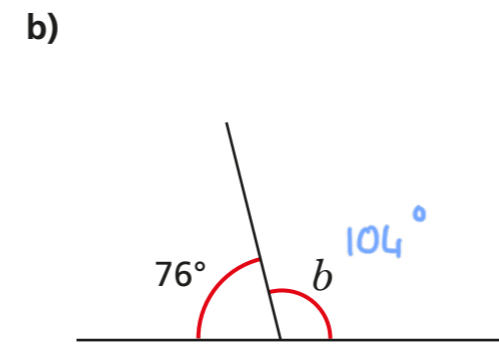
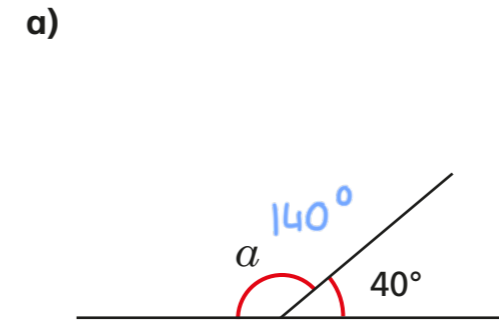

3 Dora draws two angles.

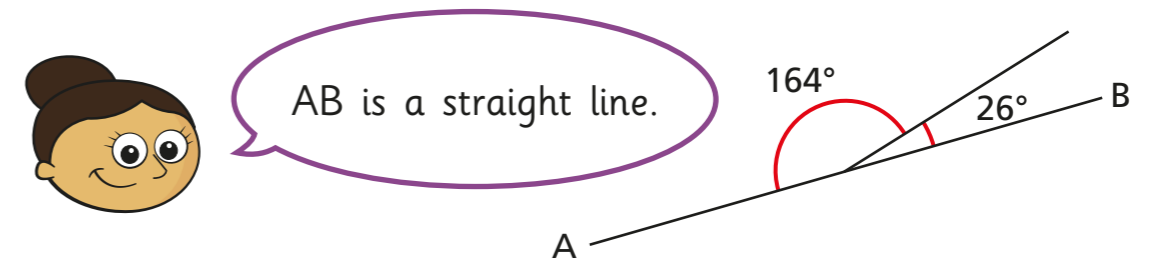

Do you agree with Dora? No

Explain your answer.

4 Work out the size of the unknown angles.

Show the steps in your working.

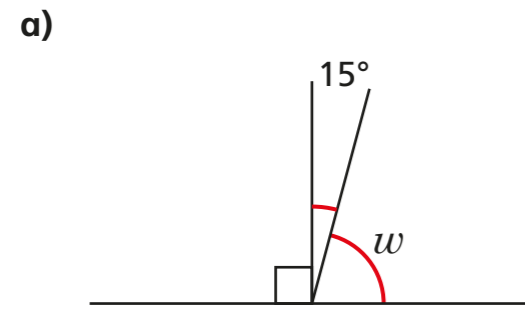

$$w = \boxed{75}^\circ$$

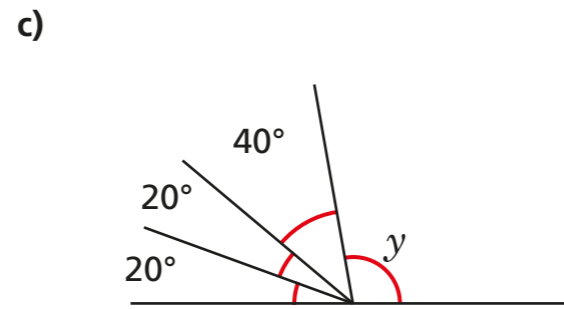

$$y = \boxed{100}^\circ$$

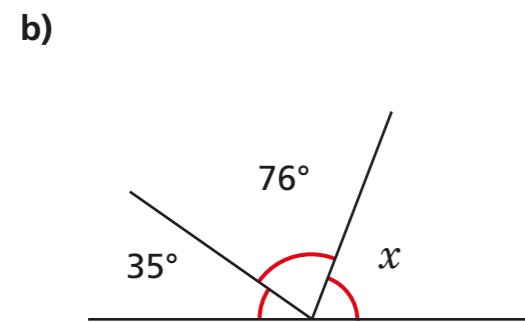

$$x = \boxed{69}^\circ$$

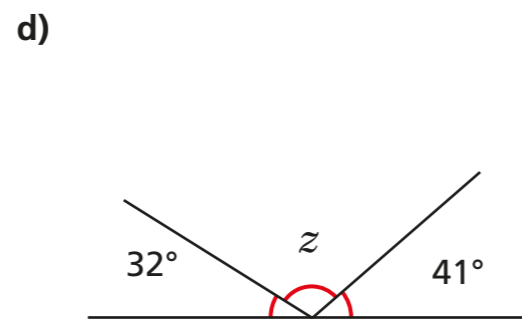

$$z = \boxed{107}^\circ$$

5 Work out the sizes of the unknown angles.

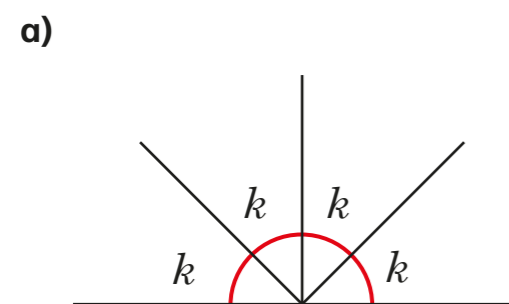

$$k = \boxed{45}^\circ$$

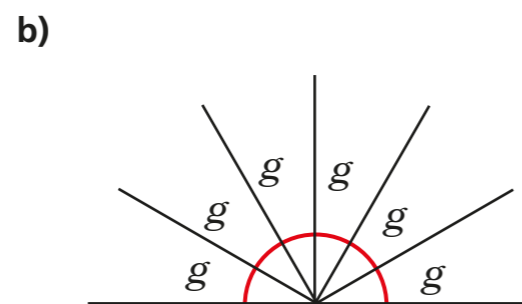

$$g = \boxed{30}^\circ$$

6 Work out the size of angle a .

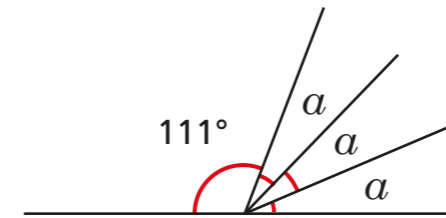

$$a = \boxed{23}^\circ$$

7 Work out the size of angle m .

Show all your working out.

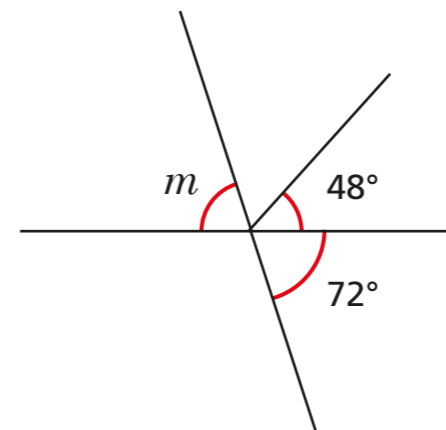

$$m = \boxed{72}^\circ$$

8 Two angles are marked.

Angle b is eight times the size of angle a .

What is the size of each angle?

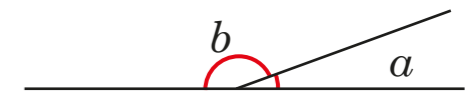

$$a = \boxed{20}^\circ \quad b = \boxed{160}^\circ$$

Calculating angles around a point

1 Work out the sizes of the unknown angles.

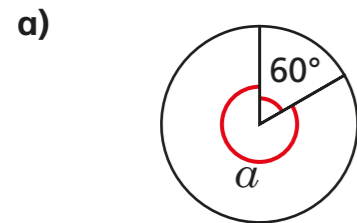

$a = 300^\circ$

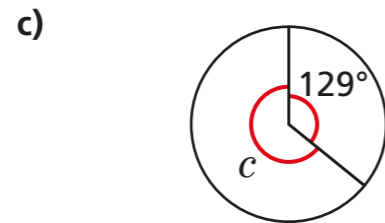

$c = 231^\circ$

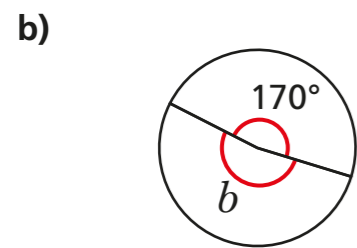

$b = 190^\circ$

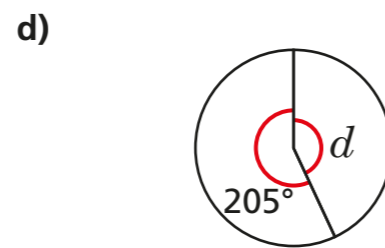

$d = 155^\circ$

2 Ron turns clockwise through 110 degrees.

He continues to turn the same way.

He wants to turn to where he was facing at the start.

How many more degrees does he need to turn through?

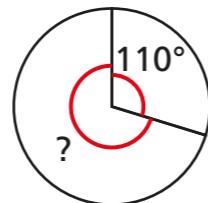

250°

3 Work out the size of the unknown angles.

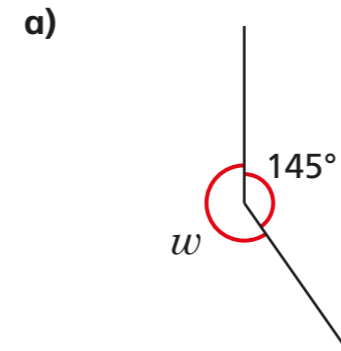

$w = 215^\circ$

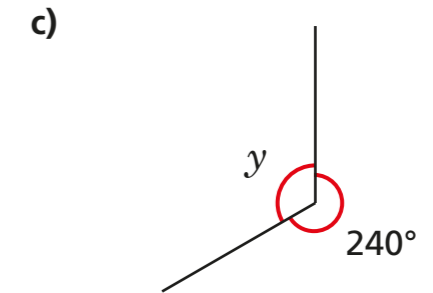

$y = 120^\circ$

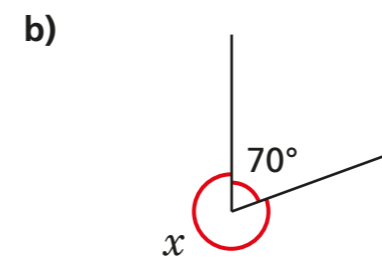

$x = 290^\circ$

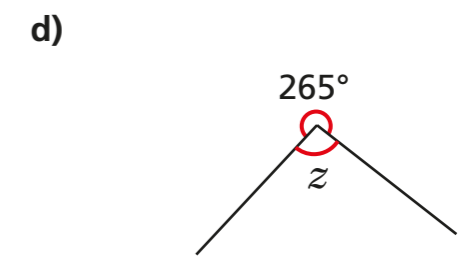

$z = 95^\circ$

4 Work out the sizes of the unknown angles.

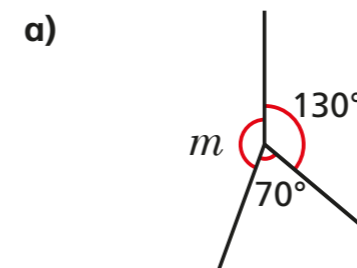

$m = 160^\circ$

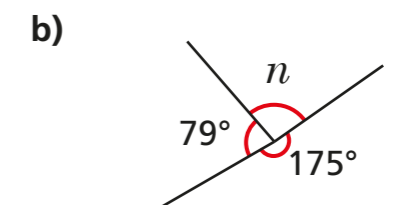

$n = 106^\circ$

5 Ms Hall asks her class to draw an angle of 250 degrees.

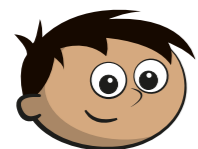

My protractor only goes up to 180 degrees.

That's true. But I think we can still use it.

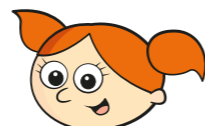

- a) Explain why Alex is correct.
- b) Draw an angle of 250 degrees.

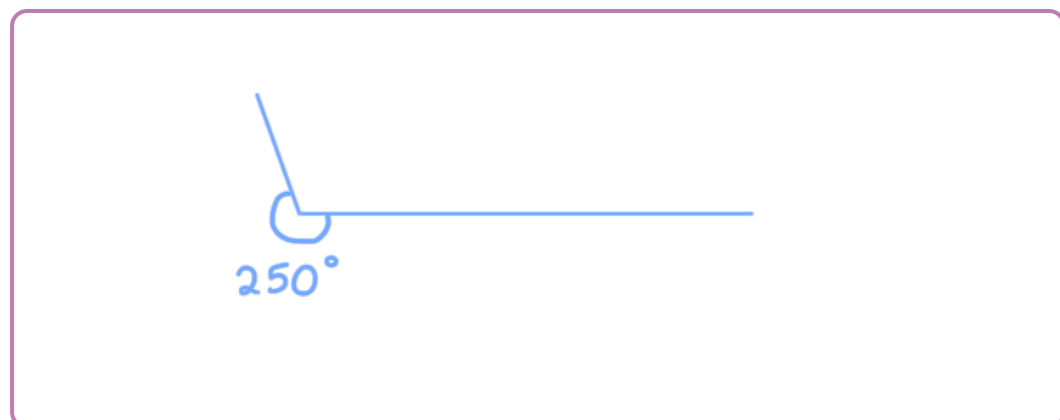

Compare methods with a partner.

6 Work out the size of angle y .

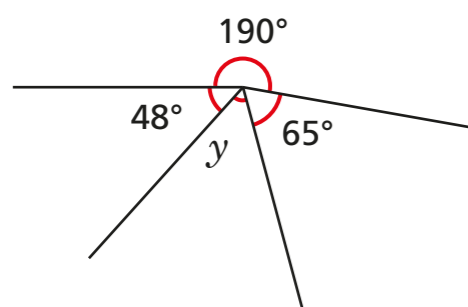

$$y = \boxed{57}^\circ$$

7 Work out the sizes of the unknown angles.

Give reasons to support your answers.

a)

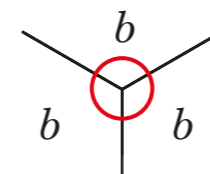

$$b = \boxed{120}^\circ \text{ because } \underline{\text{angles around a point sum to } 360^\circ \text{ and } 360 \div 3 = 120}$$

a point sum to 360° and 360 ÷ 3 = 120

b)

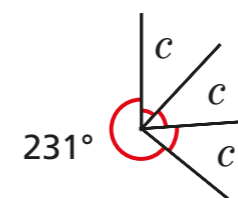

$$c = \boxed{43}^\circ \text{ because } \underline{\text{angles round a point sum to } 360^\circ, 360 - 231 = 129 \text{ and } 129 \div 3 = 43}$$

sum to 360°, 360 - 231 = 129 and 129 ÷ 3 = 43

8 A circle is divided into ten equal sections.

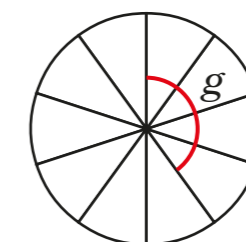

What is the size of the angle marked g ?

$$g = \boxed{144}^\circ$$